

MAGNETIC PISTON & GMR SENSORS

When ordered with the M option, an extra rod is added to the AFO for mounting and positioning the switch.

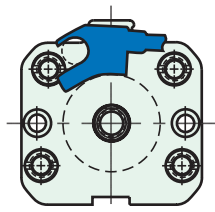

5/8" Bore

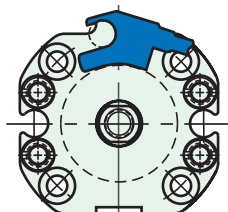

3/4" Bore

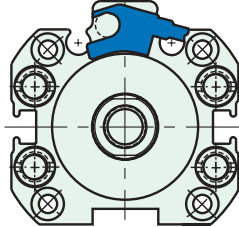

1 1/16" Bore

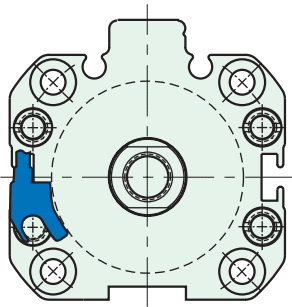

1 1/2" Bore

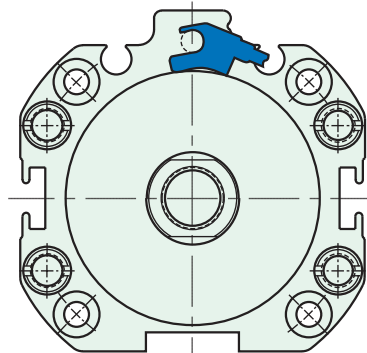

2" Bore

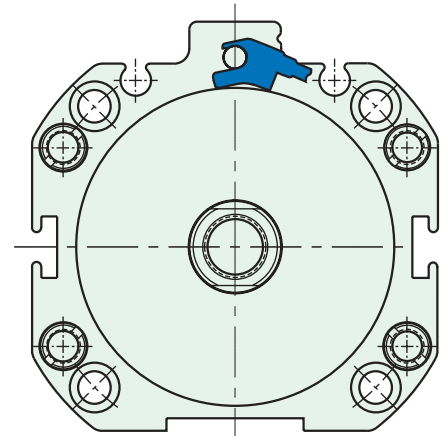

2 1/2" Bore

GMR SENSORS

Position Sensing Switch

Clippard offers the solid state circuitry of the GMR Switch to reliably detect the presence of a magnet attached to the piston. Clippard's GMR Switch incorporates an LED to visually show switch actuation. The GMR Switch is offered in sinking (NPN) and sourcing (PNP) and with a variety of cable configurations.

Locating GMR Sensors on Cylinders

Cylinders ordered with magnetic pistons come with an additional attached rod* on which the GMR Switch can be attached. The Switch snaps onto the rod and can be slid into the desired location. A set screw is used to lock the GMR Switch in place.

* Additional rod is not used on 1 1/2" Bore Cyl. GMR Switch can mount directly to any tie rod.

